

HIPPOCAMPE LEISURE WHEELCHAIR



Instructions for use and assembly

SUMMARY

GET TO KNOW YOUR HIPPOCAMPE	3
MOUNTING THE WHEELS.....	4
ASSEMBLING THE PUSH BAR	4
ASSEMBLING THE RECLINING BACKREST	5
ASSEMBLING THE RECLINING AND ADJUSTABLE BACKREST	5
ASSEMBLING THE ARMRESTS.....	6
ASSEMBLING THE HEADREST	7
ASSEMBLING THE HARNESS	8
ASSEMBLING THE BRAKES.....	8
MOUNTING THE LARGE BEACH WHEELS.....	9
MOUNTING THE BACK SKIS	10

GET TO KNOW YOUR HIPPOCAMPE

Congratulations! You have just purchased a Hippocampe wheelchair, the leisure and multi-activities Hippocampe wheelchair of Vipamat.

The Hippocampe wheelchair created and manufactured by Vipamat allows you to: go to the beach, along seaside, go into the water and go swimming, follow forest trails and coastal paths, go around gardens, and along the snowy paths.

It has been designed for disabled people of all ages. The Hippocampe can be used alone or accompanied, and several accessories can be added on: a neoprene harness, a headrest, adjustable armrests, an adjustable backrest, parking brakes, a backrest bag, a ski kit and a transport bag...

There are 4 sizes (in length) of wheelchairs S, M, L, and XL: only the frame length changes, the width of the seat is always 40 cm, but the Hippocampe wheelchair can be equipped of a wider rear axle in order to get a space of 53 cm between the wheels. The Hippocampe is approved for a maximum sitting user of 130 kgs.

FIRST USE

As this is the case with classic wheelchairs, there is a period of adaptation for using the Hippocampe.

For safety reasons, the user must be sitted as far back in the seat as possible when the wheelchair is pushed, the back of the body on the the backrest.

The exterior wheel serves as a hand rim for the autonomous use, the grip inside the rim provides better handling.

You can turn the Hippocampe:

- By forcing the front wheel to skid (to the right or left).
- By turning on "2 wheels" alone or with help (the helper has to push down on the handle bar).

When entering water, the buoyancy of the front wheel means you will need to lean forward in order to remain stable on the Hippocampe.

The level of the water immersion for the Hippocampe wheelchair must not exceed the seat height (for a good stability).

A helper will help you to ensure stability by holding the handlebar.

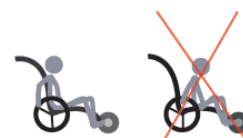

USUAL CAUTION

Before any use of the wheelchair, check that the wheels are correctly locked (by the clips), that the straps are suitably tightened and that the buckles are fastened (see operating instructions).

For safety reasons, the user must be sitted as far back in the seat as possible when the wheelchair is pushed, the back of the body on the the backrest.

The Hippocampe is approved for a maximum sitting user of 130 kgs.

The Hippocampe is not a boat, it allows entering into water up to the height of the seat and is not designed to float with the user in it.

For bathing, wearing a lifejacket is obligatory, as its use within a guarded swimming area.

Precaution for the water entering:

It is recommended that you lean forward (the buoyancy of the front wheel may unbalance backward).

A helper is required for entering into the water and swimming.

Users must be pushed exclusively by capable adults.

Watch out for the incoming tide, currents and shore breaks.

For wheelchairs not equipped with brakes we recommend the utmost caution on beaches and steep slipways.

Do not use the Hippocampe when a wheel is punctured or flat.

Using the Hippocampe with more than one person in it is prohibited.

Standing up on the seat or the footrest guard is prohibited.

Modifying the structure of the wheelchair is prohibited.

Avoid going under obstacles with the wheelchair.

Avoid hand-braking on steep surfaces due to the risk of heating and injuries.

Do not move about on slopes greater than 15%.

Do not clear obstacles larger than 10 cm.

The seat is designed not to catch fire (within 15 seconds) on contact with cigarettes or matches.

You must always be accompanied, especially for entering into the water, when you use a harness.

The strict adherence to the recommendations and advises writing on this document is imperative.

GUARANTEE, SERIAL NUMBER, AND PRODUCT'S LIFETIME

This product is guaranteed 2 years for parts and labor starting from the date of purchase (as proved by the sales receipt). The guarantee consists in replacing defective parts. This guarantee does not apply when the product is used for unauthorized purposes and does not take into consideration the normal wear of parts of the wheelchair. In view the condition in which the Hippocampe can be used, its expected lifetime is 4 years after the purchase date.

The product's serial number is located on the label placed on the rear axle of the frame and engraved on the frame's rear axle.

Each option has its own serial number engraved on the accessory.



CAUTION

The Hippocampe wheelchair is water-resistant, its aluminium, plastic and stainless steel components come from the nautical and bicycle industries. But, like all materials that come into contact with seawater (wetsuits, kayaks, boat engines, etc.), the Hippocampe must be rinsed after any use. Without this regular maintenance, salt deposits can damage its structure.

The Vipamat Company denies any responsibility concerning damages due to such negligence.

MOUNTING THE WHEELS

1. Insert slowly the end of the half wheel axle into the hub and next into the rear frame axle by pressing the clip (without pinching fingers).
2. Turn the wheel axle and guide the clip out of the hole by turning the wheel axle.
3. Verification: by exerting a pressure on the clip, it goes out of the rear axle of the frame.

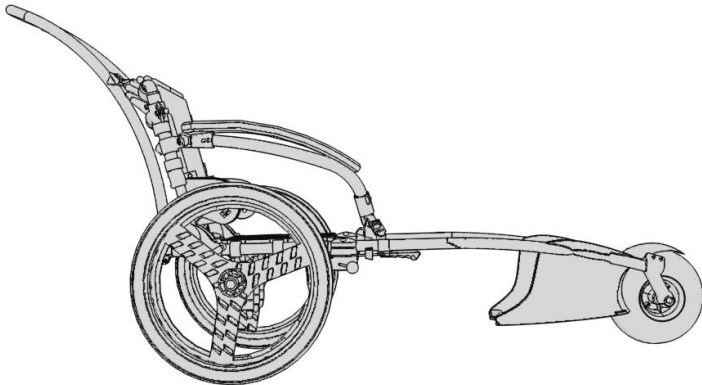
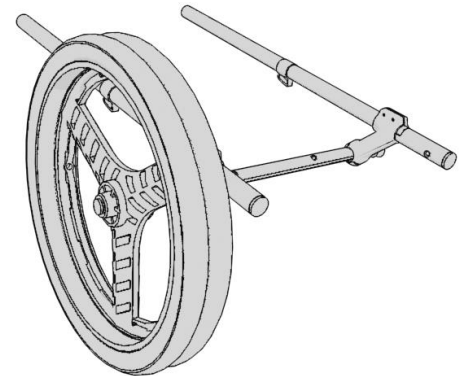
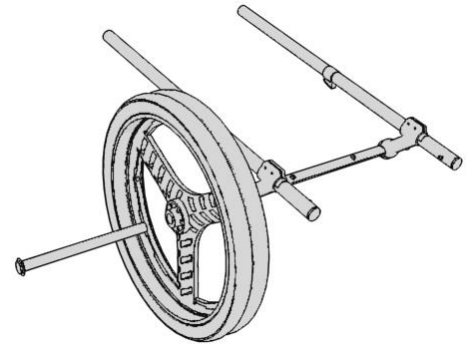

Advices to inflate the wheels:

- You can change the tyre pressure from 0.5 bar for soft sand to 1.5 bar for solid ground.
- The front wheel is a low-pressure wheel, she has a function of shock absorber and avoids to get stuck.
- It can be inflated with an inflating needle.



Caution: the diameter must not exceed 250 mm to avoid that the wheel rubs with the front footrest of the Hippocampe.

ASSEMBLING THE PUSH BAR

1. Insert the 2 joints parts into the extremities of the frame tube (up to the clips).
2. Press the 2 clips simultaneously, while pushing the handlebar, until they come out.
3. Verification: by exerting a pressure on the clip, it goes out of the push bar's gallews.

NB: The serial number is engraved on the bottom part of one of the vertical tube.

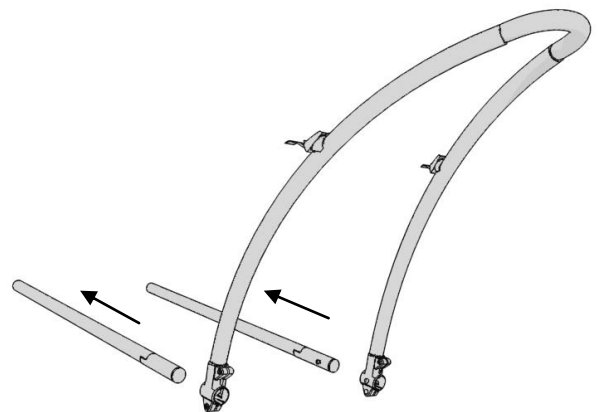

ASSEMBLING THE RECLINING BACKREST

1. Position the backrest on the frame tubes.
2. Fix the backrest to the frame: insert the nuts (b) in the screw marks and fasten the bolts (a) with the Allen key provided.
3. Verification: the backrest must tilt forward, the screws must go out the nuts at least 3 mm.

Fasten the seat (do it after the armrests and headrest installation)

4. Slide the 2 vertical straps through the buckles and tighten (figure 1).
5. Buckle the 2 wide horizontal straps and tighten well with the strap loops (figure 2).
6. Buckle the small diagonal side straps, pulling them around the tube of the backrest.
7. Verifications:

- check that the 2 vertical straps of the seat cross the strap loops and are tightened.
- check that the buckles of the wide horizontal straps (40 mm) stay locked and stretched, and that they pass through the seat's holes.
- check that each small diagonal side straps turn are pulling around the vertical tube of the backrest (for each side), that they are stretched when the backrest is up, and finally that the buckles are well locked.

NB: the serial number is engraved on the bottom part of the vertical tube.

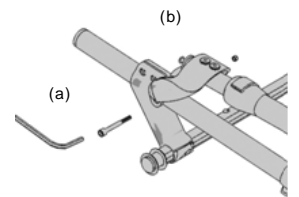

(a) CHC M6 X 45 A2
(b) M6 A2
(c) Screw RD M8X40

1

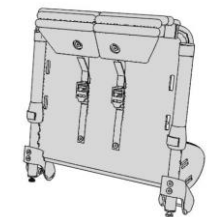

2

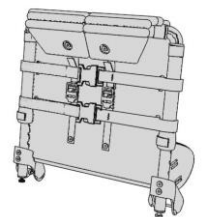

3

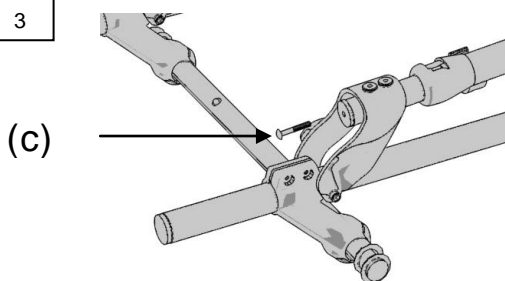

Adjusting the inclination of the backrest: to adjust the inclination, adjust the tightness of the 2 screws (c) at the base of the backrest (figure 3).



Attention: the 2 screws must be adjusted similarly.

ASSEMBLING THE RECLINING AND ADJUSTABLE BACKREST

See "Assembling the reclining backrest" instructions (above).

To adjust the height of the adjustable backrest:

1. Unfasten the 2 horizontal buckles on the back of the backrest and loosen the vertical straps.
2. Open the push locks on the backrest tubes
3. Position the backrest at the desired height and close the push locks on the positioning holes
4. Buckle the horizontal straps and tighten the vertical straps.
5. Verifications:
 - check the locking of the push locks on their positioning holes.
 - check the locking of the seat's straps: see the instructions above.

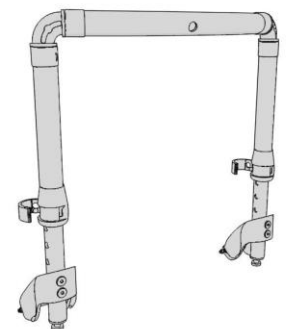

NB: The serial number is engraved on the bottom part of one of the vertical tube.

ASSEMBLING THE ARMRESTS

Disassembling the top part of the backrest

1. Unscrew the 2 screws with a crosshead screwdriver. (Figure 4)
2. Separate the top of the backrest from the two arms.

Assembling the armrests

The armrests are composed of a left and right armrest, both of which are removable, and 2 parts (d) fixed on the backrest once assembled.

3. Insert the parts (d) from the armrests into the vertical arms of the backrest.

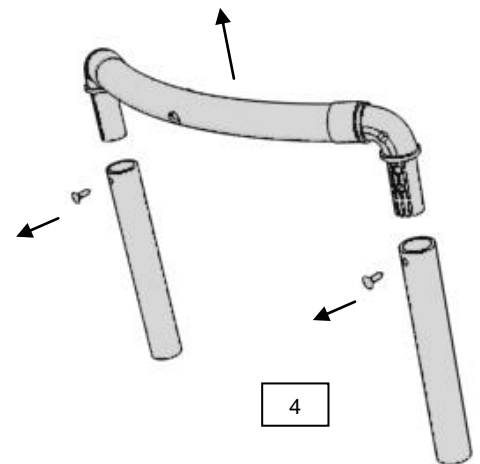

! Caution: in case that you have to assemble the headrest, go directly to step 5 "Verification".

4. Replace the top of the backrest and tighten back the 2 screws in. (Figure 4)

5. Verifications:

- the armrests once installed are positioned above the wheels.
- the butterfly screws (d) are placed at the back, inside side of the backrest.
- the top of the backrest has to be fully inserted in the vertical tubes of the backrest.
- the locking screws of the backrest must be fully tightened and the top of the backrest must be stable.

NB: The serial number is engraved on the bottom part of the 2 armrests tubes.

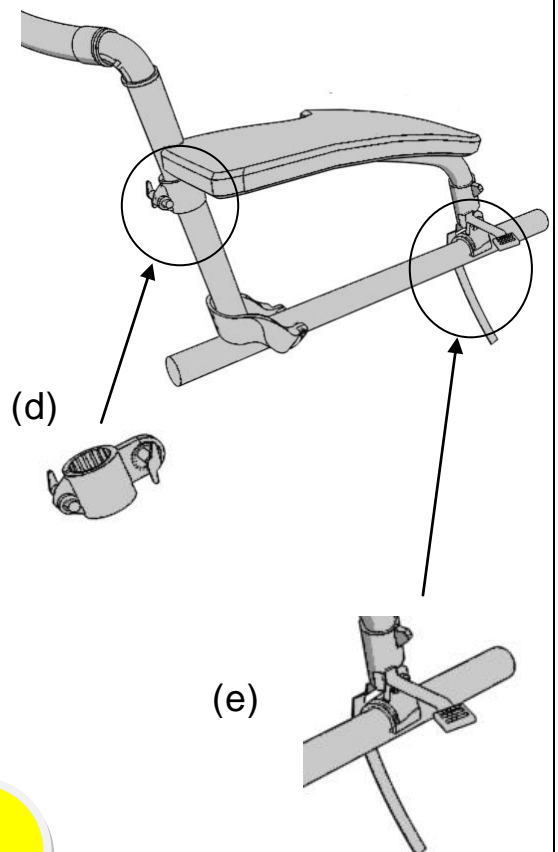

Adjustment:

To adjust height, position the armrest at the desired height and tighten the 2 wing nuts (d).

Put the back part (e) of the armrests on the frame tube. Wrap the small strap around the tube, then put it through the buckle and tighten.

Verification: check the passage of the strap around the frame tube and the clam of the low part of the armrests.

ASSEMBLING THE HEADREST

Assembling the headrest

The headrest is composed of 2 parts (Figure 8):

- the removable part (headrest + the articulated element) (f)
- the fix part (vertical tube + the bend of the horizontal tube) (g)

1. Begin by disassembling the backrest (Part "Disassembling the backrest" Figure 4 page 6).

2. Fix the headrest horizontal bend on the backrest's arms (Figure 5).

3. Replace the top of the backrest with the fixation's screws (Figure 6).

4. Fit the vertical tube on the top of the backrest and on the headrest bend (Figure 7). (Line weld forward)

5. Tighten all the screws and position the cache-nuts.

6. Fit the removable part of the headrest to the fix part (Figure 8).

7. Verifications:

- the well-positioned of the vertical tube pieces, and of the horizontal tube.
- the good clamping of the screws of the plastic pieces (with the Allen key).
- the good clamping of the screws and nuts on the tubes with the Allen key and the flat wrench of 10 (no play in any of the parts).

NB: The serial number is engraved on the vertical tube fixed on the backrest.

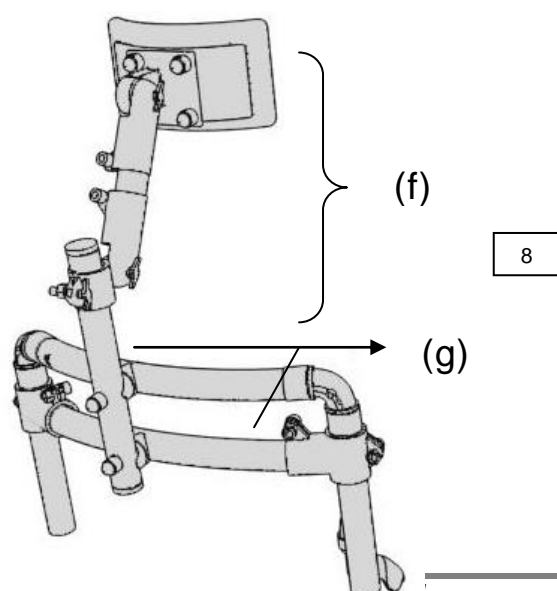
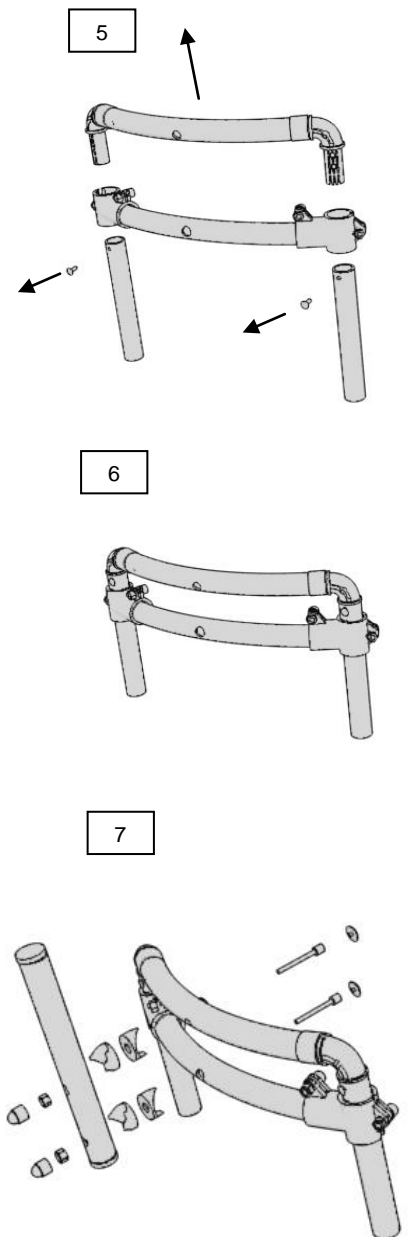

Multi-position adjustment:

Begin by loosening the 3 butterfly screws, after positioning the headrest pad in the correct position (in contact with the head). Immediately tighten the butterfly screws.

Lower butterfly screw: height + rotation adjustment

Central butterfly screw: forwards-backwards adjustment

Upper butterfly screw: forwards-backwards adjustment

Verification: the butterfly screws have to be correctly tightened, and the headrest has to be stable.

ASSEMBLING THE HARNESS

The push bar must already be assembled.

Position the harness

1. Place the upper harness straps in the handlebar clasps and fasten them (Figure 9).
2. Slide the lower harness strap through the loops (for each side).
3. Place the lower straps outside the flanges, between the seat and the frame tube, then pull the strap up after passed it beneath the tube.
4. Slide the strap back through the loop and tighten. (Figure 10)
5. Verifications:
 - the positioning direction of the harness (check the figures 9 and 10).
 - check the locking straps by stretching on each strap, the assembly must be stable.

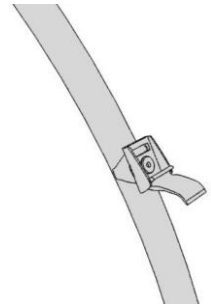

9

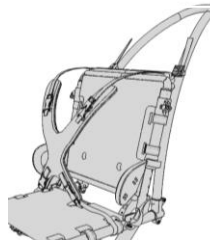

10

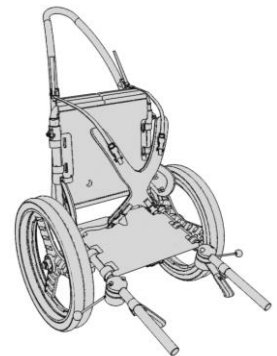

Adjusting the harness: pull on the buckles at the ends of the harness straps to tighten them. **Quick removal:** unfasten the 4 buckles.

ASSEMBLING THE BRAKES

Beforehand, check that the tyres pressure is equal to 1,5 bar.

1. Unfasten 2 buckles on the front straps under the seat.
2. Position the lower part of the brake block under the tube in contact with the camcleat at the front.
3. Position the upper part of the brake block on the frame tube in contact and at the front of the camcleat, then tighten the upper part of the brake block by tightening the 2 screws alternately.



Caution: the tightness between the upper part and the block must be practically the same on both sides. Ensure that the stem is horizontal in relation to the tyre before finishing the tightening.

4. Position the brakes camcleats and loosely screw in the tightening screws to be able to adjust the camcleats.
5. Lock the brake by jamming the handle on the camcleat (the stainless steel stem is then in contact with the tyre).
6. Position the camcleat by exaggerating the locking of the brake on the wheel and tighten the camcleat screws.
7. Verification:
 - the brakes blocks must be stable on the frame tubes (no sliding or rotating).
 - the locking brakes must block the tyres by pressing them for an efficient braking.

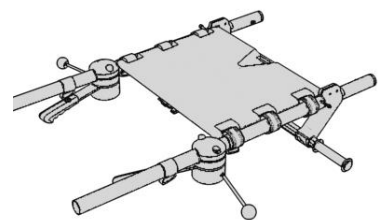
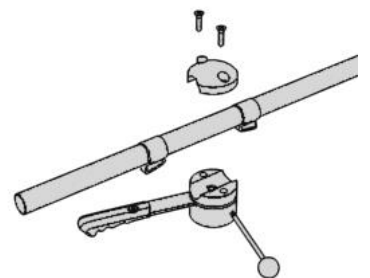

MOUNTING THE LARGE BEACH WHEELS

1. Set aside the wheels, the half-axle's wheels, and the plastic spacers.
2. Assembly of the kit for the chassis reinforcement:

The kit includes:

Designation	Quantity
Knobs to cover the nuts	12
Metal A4 M6x18	12
Screws TH A2 M6x80	6
Nuts A2 M6	6
Half collars 325 PA	12
Support axle (bar)	1

3. After making sure that you have all the parts of the kit, mount the half collars of 25 on their respective axles without forgetting the metal rings and thigten fully (see the figures).



Caution :

Before any traveling by plane, please deflate the wheels with an inflating needle.

4. Rotate vertically all the kit of reinforcement chassis and tighten fully in starting with the back screws.
5. Place the black covers on the nuts.
6. Insert the half-axle into the balloon wheels, then the plastic spacer (h) on the half-axle, and clip all on the frame.
7. Verifications:
 - check the good vertical positioning of the reinforcement kit that must be centered on the rear axle of the frame.
 - check the assembly clamping of the reinforcement kit (fully tightened) with the keys.
 - check the exit of the half axle's clips in the rear axle in pressing on the clip and in checking its exit.

NB: the serial number of the balloon wheel option is engraved on the reinforcement kit.

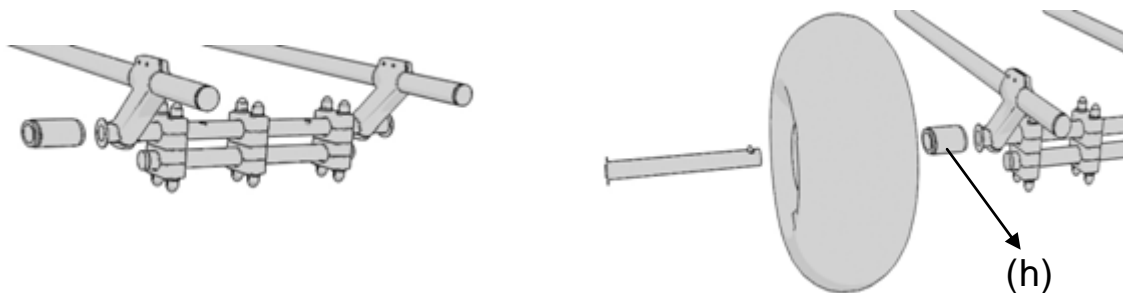
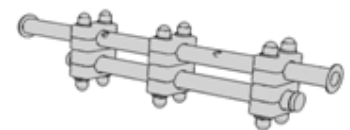
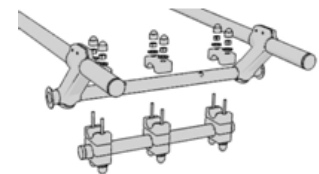
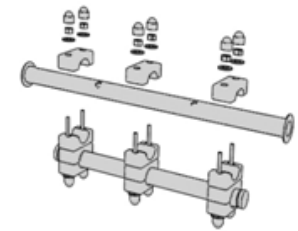
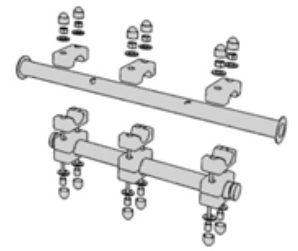

MOUNTING THE BACK SKIS

The back ski kit comprises (Figure 11) :

- 2 skis « feet + snowboards »
- 1 red safety strap

1. Remove the rear wheels half-axes by pressing on the clip of the half-axes.
2. Insert the half-axes in both skis feet (a) + (Figure 12).

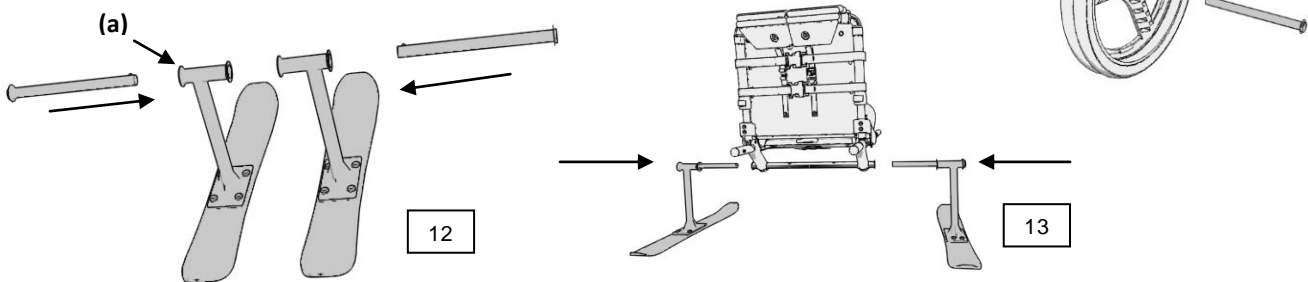

3. Insert the half-axes on the frame in ensuring that the clips lock securely on the frame's rear axle (Figure 13).
 4. Fasten the red safety strap on one of the back gallows of the frame when a helper pushes the Hippocampe with the push bar, or on one of the front gallows when a helper pulls the Hippocampe with the towrope (Figures 14 and 15).
 5. The helper must put the strap on his wrist for each use.
 6. Verification:
- check the exit of the half axle's clips in the rear axle in pressing on the clip and in checking its exit.

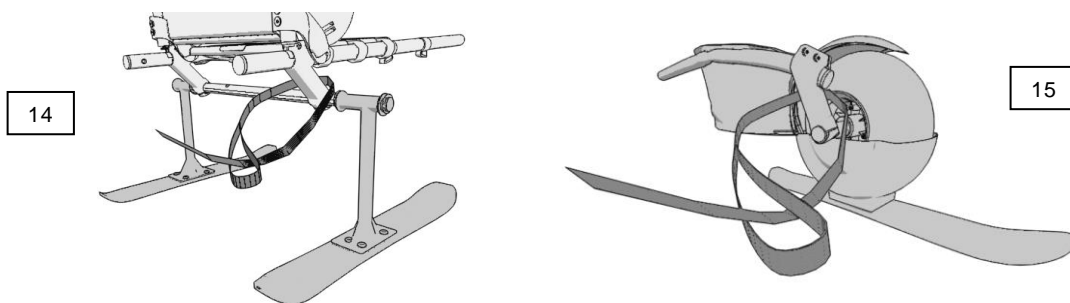

Use of the Hippocampe with the 3 skis kit:

- Use the Hippocampe on ski slopes or on luge tracks is prohibited.
- It is imperative to use the Hippocampe equipped of the 3 skis kit with a helper who has the capacity to hold the Hippocampe with his user and to maintain the security strap.
- It is imperative that the helper maintains the security strap on wrist: it must be fastened laterally on the gallows of the frame, or on one of the front gallows when the Hippocampe is pulled.
- Do not go on snowy slopes higher than 10%.
- Wearing a helmet is also recommended.

NB: The serial number of the front ski is engraved on the ski and for the rear skis on one of the vertical tube of the skis feet.



VIPAMAT

3 rue Gustave Eiffel
56 270 PLOEMEUR – France

Tel : +33 (0)2 97 86 24 87
Fax : +33(0)2 97 86 73 81

Email : contact@vipamat.com
www.vipamat.com

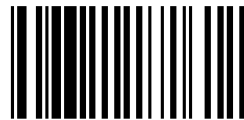

SARL au capital de 40 000€ - Siret 44242884300035 – Code APE 3092 Z

